

**WJ-8627-X**  
**20 MHz - 440 MHz**  
**VHF/UHF RECEIVERS**

# WJ-9040

**RECEIVERS**

Rev. A, 6/84



Weight - 12 lbs (5.4 kg)  
Power - 14 watts

**MODULE SIZE:**

Quarter-Rack

**AVAILABLE OPTIONS:**

Dual Bandwidth IF  
Wideband (200 kHz - 2 MHz) IF

**MODULE I/Os:**

- (A1J1) RF Input
- (A1J2) SM Output
- (A2J1) Selected Video Output
- (A2J2) IF Output
- (A3J2) 50 MHz Reference Input
- (A3J3) Auxiliary I/O (9 Pin SRE Female Connector)

SMA Female  
Connector

**Pin Assignments:**

- A - Ground
  - B - FM Audio Output
  - C - AM Audio Output
  - D - Signal Strength Output (Analog 0 to +10V)
  - E - Carrier Operated Relay Control (open collector, 30 mA sink to ground for switching +24 V maximum external voltage)
  - F - Carrier Operated Squelch
- (A3J1) WJ-9040 System Connector (25 Pin, Type "D")  
(see page four for pinouts)

**REQUIRED ADDITIONAL EQUIPMENT:**

- EFR100 Series Equipment Frame
- EPS100 Series Power Supply
- FRM/SRM1XX Series Site or Frequency Reference Module
- IOM108 I/O Module

**COMPATIBLE ACCESSORY EQUIPMENT:**

- DIO232, DIO488 Interface
- SSU1XX Series Signal Switching Units
- SMU120 Signal Monitor Unit
- SPN108 Speaker Panel
- DDF108 Direction Finding Unit
- WJ-8628-4 VHF/UHF Scanning Receiver
- WJ-8626-4 HF Receiver and Controller

**FEATURES**

- Four receivers covering 20-440 MHz frequency range
- Low power consumption
- One-quarter rack, modularized construction
- Low phase noise, high speed synthesizers
- 100 Hz tuning resolution.
- Remotely controllable
- Tunable preselection
- Wide dynamic range
- 10 kHz - 2 MHz Field Changeable Bandwidths

**DESCRIPTION**

The WJ-8627 Series of VHF/UHF Handoff Receivers function as intercept, Handoff, and monitor receivers in the WJ-9040 System. Frequency coverage from 20 to 440 MHz is accomplished in four bands: 20 to 100 MHz, 100 to 180 MHz, 180 to 300 MHz and 220 and 440 MHz, all in 100 Hz steps. To achieve the wide dynamic range of the receiver, the front end low noise amplifier stage is preceded by a voltage tuned preselector with a nominal bandwidth equal to or less than 10% of tuned frequency. This preselector is continuously tunable, insures high image and IF rejection, minimal local oscillator radiation, and improved intermodulation and spurious response in dense signal environments. All tuning is performed via frequency synthesized local oscillators exhibiting very low phase noise (-95 dBc/Hz at 10 kHz offset) and resulting in an ultimate receiver signal-to-noise ratio of 45 dB.

Detection modes for this series of receivers are AM and FM through a single IF Bandwidth filter (Dual IF Bandwidth Module optional). This filter's bandwidth is optional, easily changed by the user, and is selected from the WJ-9927-XX Series of IF Filter sets, varying in bandwidth from 10 to 200 kHz (200 kHz - 2 MHz optional). Tuning, detection mode selection, gain control, audio output, signal strength, AFC, and COR functions are operating parameters remotely accessed through a serial data stream provided by the Equipment Frame IOM108, I/O Module.

Reliability and ease of maintenance are inherent to the construction of the receivers. These quarter-rack VHF Receivers feature a hinged chassis design resulting in easy access and superior EMI/RFI isolation and shielding between receiver functions.

**CAPABILITIES AND APPLICATIONS**

The WJ-8627-X Series of VHF/UHF Receivers may be used as either scanning, remotely controllable units or as handoff or monitor receivers in larger systems.

The receivers operate in conjunction with the IOM-108 I/O Module which stores up to 99 channels or 16 sectors

**WJ-8627-X**  
**20 MHz - 440 MHz**  
**VHF/UHF RECEIVERS**

**RECEIVERS**

Rev. A, 6/84

per equipment frame and will perform either channel or FI-F2 scans. Threshold and dwell are adjustable for each channel or sector. Since these receivers occupy only one quarter of a standard 19 inch frame, up to four identical receivers may be installed in a frame and the probability of intercept in the scan mode will increase dramatically. This is useful when only a certain portion of the VHF/UHF band is of interest.

The receivers may also be used in a handoff mode in conjunction with 20-500 MHz fast scanning head end receivers such as the WJ-8628-X. When used this way, numerous frequencies may be monitored with a system requiring minimum rack space, power and cost.

The receivers may also be controlled by the WJ-8626A-4 HF Receiver and Controller thus allowing HF/VHF/UHF coverage in a single equipment frame.

**SPECIFICATIONS**

	<u>WJ-8627-2</u>	<u>WJ-8627-4</u>
Frequency Range	20 to 100 MHz	100 to 180 MHz
Image Rejection	80 dB min.	70 dB min.
IF Rejection	80 dB min.	80 dB min.
Noise Figure	10 dB max.	9 dB max.
	<u>WJ-8627-5</u>	<u>WJ-8627-6</u>
Frequency Range	180 to 300 MHz	220 to 440 MHz
Image Rejection	80 dB min.	80 dB min.
IF Rejection	70 dB min.	70 dB min.
Noise Figure	10 dB max.	10 dB max.
Detection Modes	FM, AM	
Tuning Resolution	100 Hz	
Synthesizer Tuning Speed	25 msec	
Phase Noise	-95 dBc/Hz maximum at 10 kHz offset frequency	
Input Impedance	50Ω, unbalanced	
Input VSWR	2.5:1 maximum	
Internal Spurious	-110 dBm	
Third Order Input Intercept Point	0 dBm, minimum	
Preselection	Tunable, nominal BW = 10% Ft	
LO Radiation	-95 dBm maximum	
SM Output	21.4 MHz with 4 MHz nominal BW	
IF Bandwidth	One (1), standard selection from 10, 20, 25, 30, 40, 50, 75, 100 or 200 kHz (200 kHz - 2 MHz optional)	
IF Output	20 mV nominal into 50Ω at AGC threshold, IF BW limited	
AM Stability with AGC	Video Output changes 6 dB maximum from AGC threshold to a level 100 dB above (or maximum input of 0 dBm)	
Manual Gain Control	100 dB	
Video Output	0.35 Volts RMS minimum into 75Ω under sensitivity conditions	
Video Response	200 Hz to 1/2 IF Bandwidth (AM) 0 Hz to 1/2 IF Bandwidth (FM)	

Squelch/COR	Adjustable threshold from noise level to 80 dB above noise. COR holds a nominal 4 seconds after carrier disappears
Signal Strength Output	Shaped DC AM detector output, 0 to +10 V
Digital Control	56 bit serial word (WJ-9040 System compatible)
Operating Temperature	0°C to 50°C
Power Consumption	14 W
Weight	12 lbs (5.4 kg)
Size	5.2 in (132 mm) high, 4.0 in (102 mm) wide, and 14.38 in (365 mm) deep

**IF BANDWIDTH OPTIONS AND SENSITIVITY**

	<u>3 DB IF Bandwidth (kHz)</u>	<u>(-2,-5,-6) RF Level (dBm)</u>	<u>(-4) RF Input Level (dBm)</u>
WJ-9927-10K	10	-105	-106
WJ-9927-20K	20	-102	-103
WJ-9927-25K	25	-101	-102
WJ-9927-30K	30	-100	-101
WJ-9927-40K	40	-99	-100
WJ-9927-50K	50	-98	-99
WJ-9927-75K	75	-96	-97
WJ-9927-100K	100	-95	-96
WJ-9927-200K	200	-92	-93
WJ-9927-250K	250	-91	-92
WJ-9927-300K	300	-90	-91
WJ-9927-400K	400	-89	-90
WJ-9927-500K	500	-88	-89
WJ-9927-600K	600	-87	-88
WJ-9927-800K	800	-86	-87
WJ-9927-1.0M	1000	-85	-86
WJ-9927-1.2M	1200	-84	-85
WJ-9927-1.5M	1500	-83	-84
WJ-9927-2.0M	2000	-82	-83

**AM** - Input signal AM modulated 50% by a 1 kHz tone, will produce a minimum video output (S+N)/N ratio of 10 dB.

**FM** - Input signal modulated at 1 kHz rate with a peak deviation equal to 30% of selected IF BW, will produce a minimum video output (S+N)/N ratio of 17 dB. (NOTE: A 400 Hz rate is required for 10 kHz and 20 kHz IF Bandwidth).

**NOTE**

WJ-9927-10K through WJ-9927-200K IF Bandwidths are used in WJ-8627-X Receivers equipped with standard IF Section. WJ-9927-250K through WJ-9927-2M IF Bandwidths are used in WJ-8627-X1 Receivers equipped with wideband IF Section.

BLOCK DIAGRAM

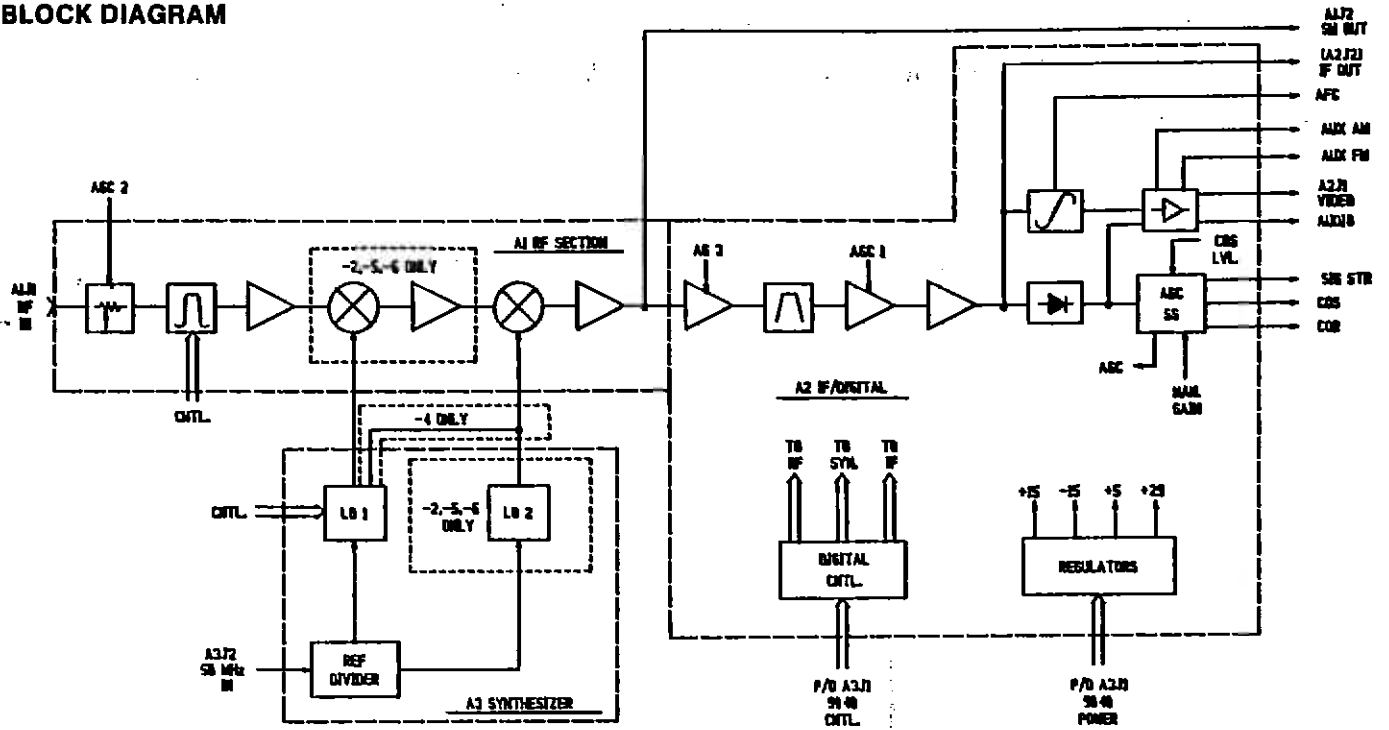

OUTLINE DRAWING

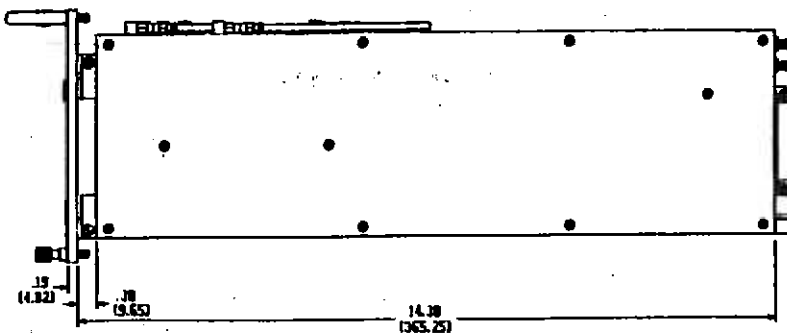
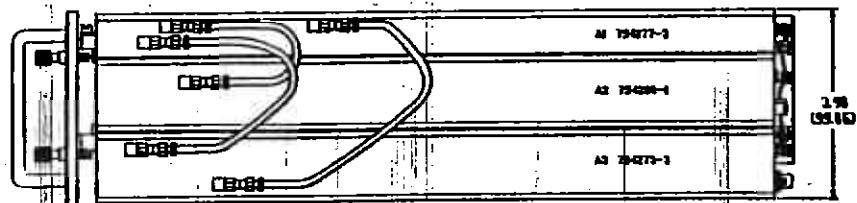
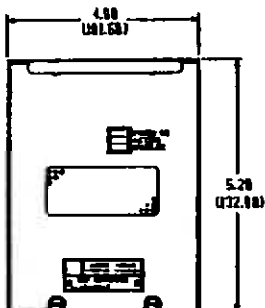
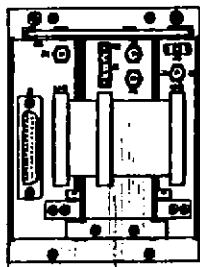

XX DIMES  
 0000 MM

**IEEE-488/RS-232 COMMANDS**

COMMAND	DESCRIPTION	COMMAND	DESCRIPTION
AFC	Turns on AFC	*F1 n,f	Sets start frequency of sector
AFC/	Turns off AFC	*F1 n?	Asks for start frequency of sector
AFC?	Asks for AFC state	*F2 n,f	Sets stop frequency of sector
AGC	Turns on AGC	*F2 n?	Asks for stop frequency of sector
AGC/	Turns off AGC	FM	Selects FM detection mode TL
AGC?	Asks for AGC state	FRQ f	Sets tuned frequency
AM	Selects AM detection mode	FRQ?	Asks for tuned frequency
BW n	Sets receiver bandwidth	INL n,m-p	Includes channels for channel scan
BW?	Asks for bandwidth #	LCK n,m-p	Locks channels out of channel scan
BWC?	Asks for bandwidth in kHz	MAN n	Stops specified a scan
CLR	Resets receiver	RCL n	Recalls a memory channel
COS n	Sets COS threshold level	RFG n	Sets RF gain level
COS?	Asks for COS threshold level	RFG?	Asks for RF gain level
CST?	Asks for COS state	SCN	Starts channel scan
DET?	Asks for detection mode	SLOT n	Addresses a specified slot
DWL n,m	Sets sector & channel dwell time	SS?	Asks for signal strength
DWL?	Asks for dwell times	STO n	Allocates a memory channel
EXAM n	Asks for slot status	*STP n	Starts a sector scan

\*Optional Commands

**COMMAND/CONTROL SERIAL BIT STREAM (Pin 14)**

BYTE	bit 7	bit 6	bit 5	bit 4	bit 3	bit 2	bit 1	bit 0
0		1 kHz Frequency				100 Hz Frequency		
1		100 kHz Frequency				10 kHz Frequency		
2		10 MHz Frequency				1 MHz Frequency		
3		1 GHz Frequency				100 MHz Frequency		
4	AFC				COS Threshold Level			
5	AGC mode sel				Manual Gain Control Level			
6	IF BW select			unassigned			Detection mode	

Effective Bit Rate = 17.1 Kbit/sec. For detailed data transfer timing, please refer to the IOM 108 I/O Module Data Sheet.

**25 PIN EQUIPMENT FRAME CONNECTOR**

1. Addressed Enable B In	15. Report Data Out
2. Strobe In	16. Logic Ground
3. Clock In	18. Power Ground 2
5. Power Ground 1	19. -18.3 VDC
6. +29 VDC	20. +8.2 VDC
7. +18.3 VDC	21. Signal Ground
9. Addressed Enable A In	22. Signal Strength
12. AFC Out	23. Synthesizer Unlocked
13. COS Status Out	24. Squelched Audio
14. Command/Control Data In	25. Not Assigned